

SLB-0124

Double Arm Side of Pole/Wall Mount

The Solarland® SLB-0124 has been specifically designed for two solarland solar panels, SLP U Series panels (50W to 180W), SLP C1D2 Series panels (45W to 150W), SLP CSA Series panels (50W to 60W) ; It is also compatible with solar panels up to 54inch on the shortest side.



Specifications

Mounting Type	Double Arm Side of Pole/Wall Mount
Module Type	Specifically designed to work with Solarland SLP series panels, but can be adapted for use with other panels
Number of Modules	Mount Two Panels
Setting Angle	0°-90°
Wind Load	Designed to withstand wind speeds of 90mph
Snow Loading	1.1kN/m ²
Warranty	5 Years

Kit Components

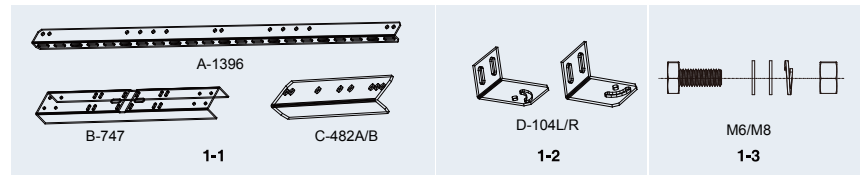
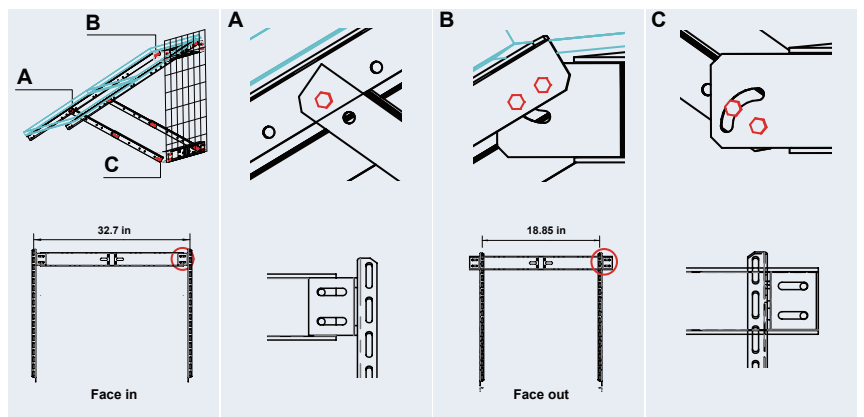

Diagram	Component	Material	Surface Treatment	Quantity	Dimensions
1-1	Fixed Bracket	Aluminum Alloy	N/A	2/2/2	A-698=55×1.97×1.1in, B-747=29.4×3.3×1.9in C-482A=19×1.7×1.1in
1-2	Fixed Bracket	Aluminum Alloy	N/A	2/2	D104L/R=4.1×3×2.5in
1-3	Bolts	Stainless Steel	N/A	8/22	M6=6×18mm, M8=8×20mm

*Note: U-Bolts or Steel Clamps are not supplied in this kit and must be procured separately if pole mount is required



Mounting Diagram



Note:

- When using this kit with another brand of panel you may need to change the module bolts to suit the mounting holes on the panel. M8 & M6 bolts are provided with this kit for your preference.

Office Address

301 Doubleday Ave. Ontario, CA 91761

Phone

tf. 1-800-605-9718 t. 1-909-937-7187
f. 1-909-533-2562

Network

Email

sales@solarlandusa.com

Website

www.solarlandusa.com