



**DEEP CYCLE**  
**SERIES: 5000**  
**MODEL: 8 CS 17P**

**BATTERY ENGINEERING**  
**WWW.ROLLSBATTERY.COM MADE IN CANADA**

**BATTERY TYPE: 8 VOLTS**

**DIMENSIONS:**

<b>LENGTH</b>	718 MM	28 1/4 INCHES
<b>WIDTH</b>	210 MM	8 1/4 INCHES
<b>HEIGHT</b>	464 MM	18 1/4 INCHES

**WEIGHTS:**

<b>WEIGHT DRY</b>	108 KG	238 LBS.
<b>WEIGHT WET</b>	133 KG	294 LBS.

**CONTAINER CONSTRUCTION:**

<b>CONTAINER: (INNER)</b>	POLYPROPYLENE	<b>TERMINALS:</b>	FLAG WITH STAINLESS STEEL NUTS AND BOLTS
<b>COVER: (INNER)</b>	POLYPROPYLENE - HEAT SEALED TO INNER CONTAINER	<b>HANDLES:</b>	MOLDED
<b>CONTAINER: (OUTER)</b>	HIGH DENSITY POLYETHYLENE		
<b>COVER: (OUTER)</b>	HIGH DENSITY POLYETHYLENE SNAP FIT TO OUTER CONTAINER		

**PLATES:**

**POSITIVE PLATE DIMENSION:**

<b>HEIGHT</b>	273 MM	10.750 INCHES
<b>WIDTH</b>	143 MM	5.625 INCHES
<b>THICKNESS</b>	6.73 MM	0.265 INCHES

**NEGATIVE PLATE DIMENSION:**

<b>HEIGHT</b>	273 MM	10.750 INCHES
<b>WIDTH</b>	143 MM	5.625 INCHES
<b>THICKNESS</b>	4.70 MM	0.185 INCHES

**CELLS:** 4      **PLATES/CELL:** 17

POSITIVE PLATE ENVELOPED BY VERTICAL SLYVER GLASS MAT

**SEPARATOR:**  
**THICKNESS**      3 MM      0.105 INCHES

**INSULATION:**  
**GLASS MAT**      1 MM      0.020 INCHES

**CAPACITY:**

<b>CRANK AMPS:</b>		
<b>COLD (CCA)</b>	0°F / -17.8°C	1357
<b>MARINE (MCA)</b>	32°F / 0°C	1696

**ELECTROLYTE RESERVE:**  
**ABOVE PLATES**      95 MM      3.75 INCHES

**RESERVE CAPACITY:**  
**RC @ 25A**      1083 MINUTES

**20 HR RATE: 546**

	<b>HOURLY RATE</b>	<b>SPECIFIC GRAVITY</b>	<b>CAP / AH</b>	<b>CURRENT / AMPS</b>
CAPACITY @	100 HOUR RATE	1.280 SP. GR.	770	7.70
CAPACITY @	72 HOUR RATE	1.280 SP. GR.	726	10.09
CAPACITY @	50 HOUR RATE	1.280 SP. GR.	672	13.43
CAPACITY @	24 HOUR RATE	1.280 SP. GR.	568	23.7
<b>CAPACITY @</b>	<b>20 HOUR RATE</b>	<b>1.280 SP. GR.</b>	<b>546</b>	<b>27.3</b>
CAPACITY @	15 HOUR RATE	1.280 SP. GR.	508	33.9
CAPACITY @	12 HOUR RATE	1.280 SP. GR.	475	39.6
CAPACITY @	10 HOUR RATE	1.280 SP. GR.	453	45.3
CAPACITY @	8 HOUR RATE	1.280 SP. GR.	426	53.2
CAPACITY @	6 HOUR RATE	1.280 SP. GR.	388	64.6
CAPACITY @	5 HOUR RATE	1.280 SP. GR.	366	73
CAPACITY @	4 HOUR RATE	1.280 SP. GR.	339	85
CAPACITY @	3 HOUR RATE	1.280 SP. GR.	306	102
CAPACITY @	2 HOUR RATE	1.280 SP. GR.	262	131
CAPACITY @	1 HOUR RATE	1.280 SP. GR.	186	186



1 STATION RD SPRINGHILL, NOVA SCOTIA CANADA B0M 1X0 1.800.681.9914

REV.2  
 Jan-10  
 8 CS 17P



PART NUMBER: 8-CS-17P

WEIGHT WET: 294 LB / 134 KG

WEIGHT DRY: 238 LB / 108 KG

CAPACITY 546 AH 20 HR

VOLTAGE: 8 V

OVERALL DIMENSIONS: 28 1/4" X 8 1/4" X 18 1/4"

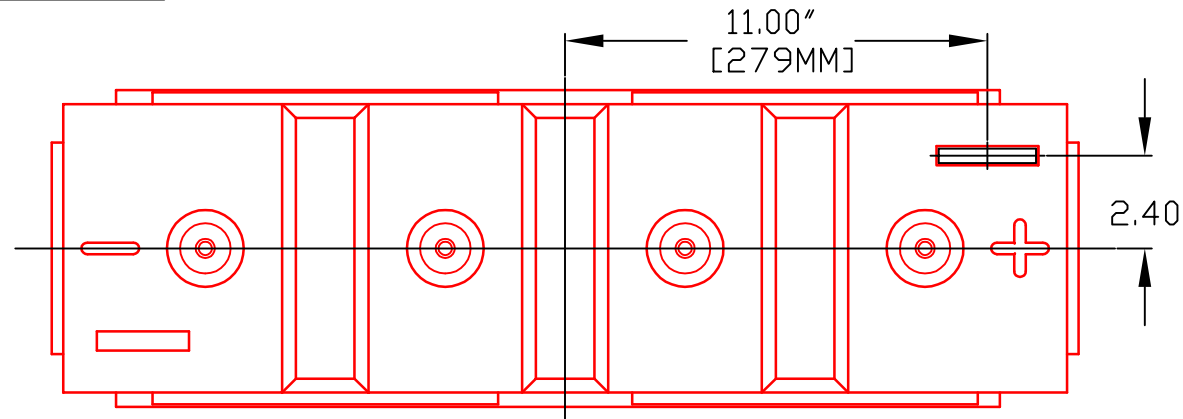

0.70" [18MM]

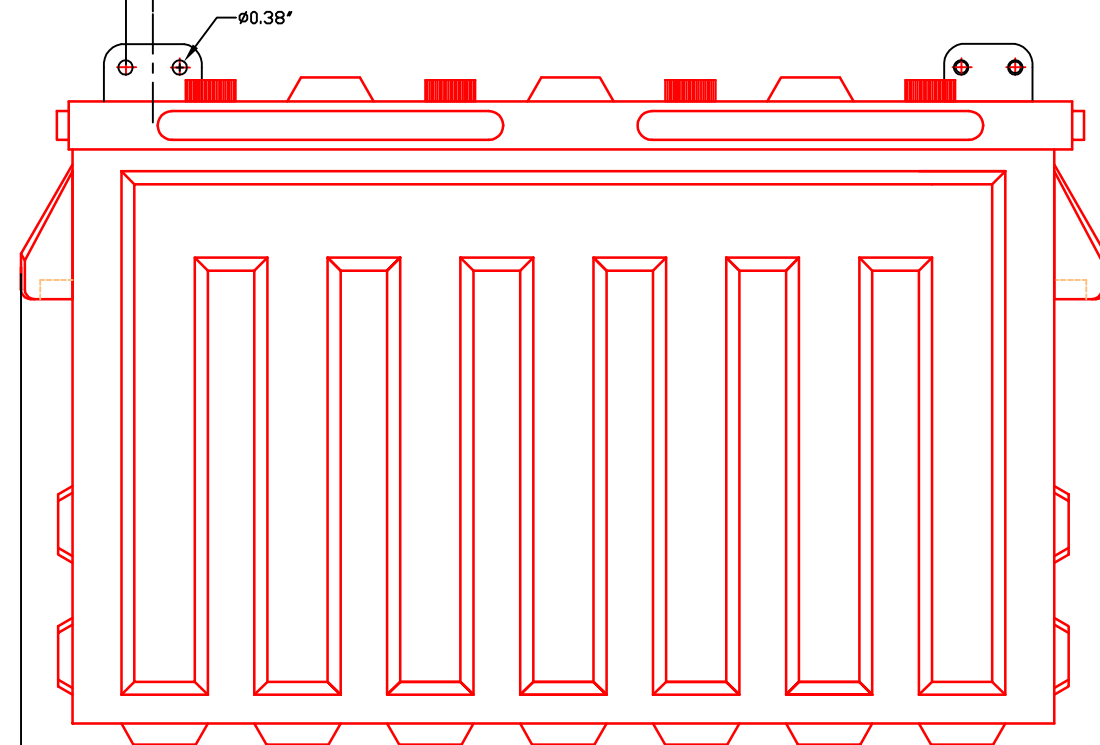

18.25" [464MM]



TITLE: 8CS17P

DESCRIPTION: 8V / 4 CELL 17 PLATE (CS) DEEP CYCLE 5000 SERIES

CONTACT INFO:  
 WEB: WWW.SURRETTE.COM  
 E-MAIL: SALES@SURRETTE.COM  
 PHONE: 1-800-681-9914

SCALE: 1" = 6" 1" = 4" JPEG:  
 8.5" X 11" 11" X 17" NOT TO SCALE

Drawn by: S. WILES Approved By: D. SURRETTE

DATE: JAN-2010 REVISION 2.0

DRAWING NO.: DWG 036, BD8CS17P